

EDGE-O-DOCKLEVELER - FM-2566

APPROX WEIGHT: 510.89 lbs.
DOES NOT INCLUDE WEIGHT OF POWER OR PACKAGING!!!

*** ANY ADDITIONS, DELETIONS, OR OMISSIONS MUST BE CORRECTED ON THIS DRAWING AS THIS DRAWING WILL BE CONSIDERED ALL INCLUSIVE ***

ALL GRAPHICS PROVIDED ARE FOR REFERENCE ONLY. IF CERTAIN DIMENSIONS ARE CRITICAL PLEASE VERIFY THOSE DIMENSIONS WITH YOUR SALESPERSON

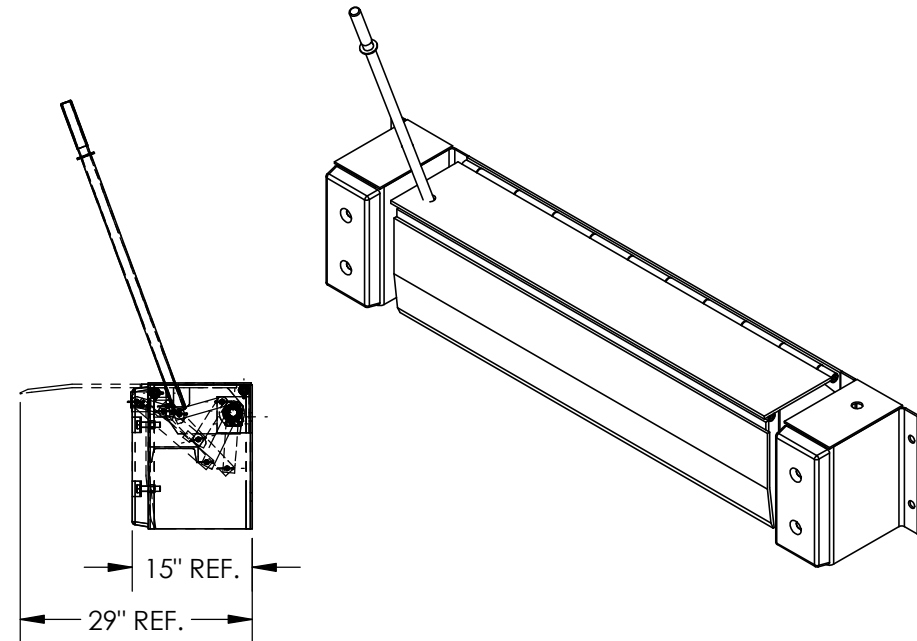
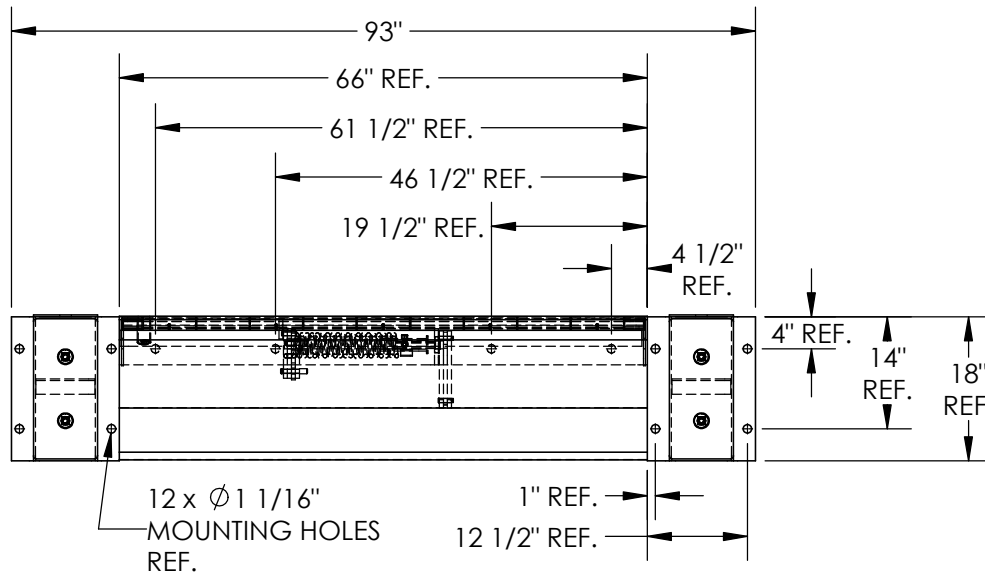

NOTE: HANDLE NOT SHOWN IN THIS VIEW

STANDARD FEATURES

- MODEL NUMBER IS FM-2566
- RAMP WIDTH IS 66", OVERALL WIDTH WITH BUMPERS IS 93"
- MAX CAPACITY IS 25,000 LBS
- STANDARD TOE GUARDS
- GREASE ZERK FITTINGS
- 18" HIGH BUMPERS (TO SERVE LOW TRUCKS)
- ADJUSTABLE TORSION SPRING COUNTERBALANCE MECHANISM
- SERVICE RANGE OF 5" ABOVE AND BELOW DOCK
- UNIT COMES WITH HANDLE AND BUMPERS

EDGE-O-DOCKS & DOCK SEALS OR SHELTERS CAN BE USED TOGETHER.
DOCK SEALS OR SHELTERS REQUIRE A 20" MINIMUM PROJECTION.

SPECIAL FEATURES

NONE

DIMENSION TOLERANCE $\pm 1/4"$

APPROVAL	I, THE UNDERSIGNED, AGREE THAT THE PRODUCT AS REPRESENTED SATISFIES DESIGN AND DIMENSION REQUIREMENTS. I ALSO ACKNOWLEDGE MY DUTY TO CONFIRM PRODUCT AND INSTALLATION COMPLIANCE WITH ALL APPLICABLE FEDERAL, STATE AND LOCAL REGULATIONS AND STANDARDS.	
	ALL SPECIAL UNITS ARE NON-RETURNABLE	
	[] As drawn [] As marked	
Signed: _____		Date: _____
LEAD TIME WILL START UPON RECEIPT OF SIGNED APPROVAL DRAWING		

DISTRIBUTOR'S NAME:		P.O.#
VESTIL MANUFACTURING		X
DRAWN BY: M.WILSON		W.O.#
DATE: 1/2/2012		X
REFERENCE: X	SCALE: 1:24	SALES: X
QUOTED LEAD TIME: X	QUOTE #	FILE NAME:
	X	07-007-007