

Bulk Mover

This popular pack-out cart is ideal for receiving wrapped and labeled products off conveyors. The Bulk Mover eliminates the use of unsanitary wire shopping carts to move bulk items through your prep room. This cart is ideal for all departments.



8040012 Shown

FEATURES:

- Sanitary aluminum
- Legs are reinforced to handle heavy loads
- Tub is constructed of sanitary, washable polyethylene
- Sanitary aluminum square tube frame

REPLACEMENT PARTS:

- Rolls easily on (4) 5" x 1.25" polyurethane swivel casters. Replacement Order #B000025



Freight Class: 300
 NMFC Code: 164390-S2

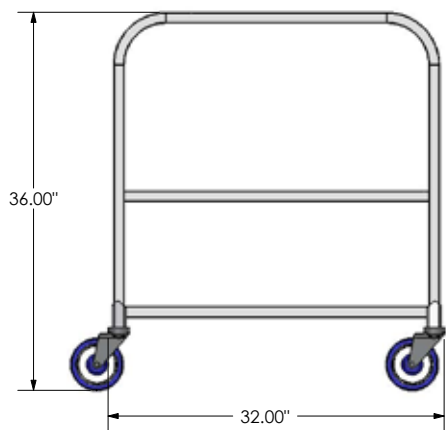
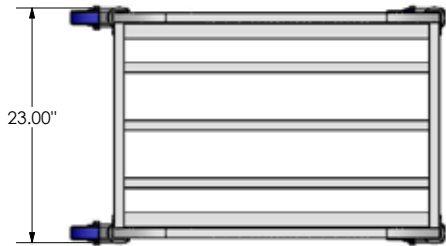

8040011

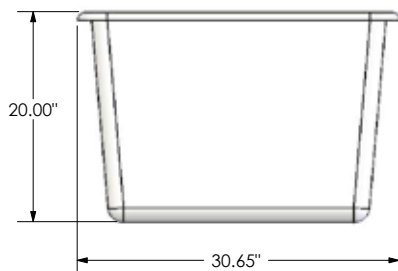
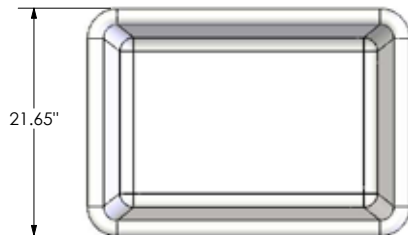
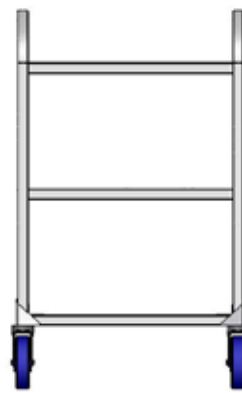

B000167



Order #	Model	Description	W	L	H	Weight
8040011	AL-2029BM, AL 6-BUSHEL BULK MOVER	Frame	20"	28"	28"	22 lbs.
B000167	BULK MOVER TUB, WHT PLASTIC SL-6	Tub	23"	33"	28"	20 lbs.
8040012	2029BMPT, AL 6 BUSHEL BULK MOVER	Frame & Tub	23"	33"	36"	57 lbs.

Can't find exactly what you need? Give us a call and we'll help you with the perfect solution!