

FORK MOUNTED DRUM CARRIER/ ROTATOR - DCR-205-8

APPROX WEIGHT: 157.43 lbs.
DOES NOT INCLUDE WEIGHT OF POWER OR PACKAGING!!!

*** ANY ADDITIONS, DELETIONS, OR OMISSIONS MUST BE CORRECTED ON THIS DRAWING AS THIS DRAWING WILL BE CONSIDERED ALL INCLUSIVE ***

ALL GRAPHICS PROVIDED ARE FOR REFERENCE ONLY. IF CERTAIN DIMENSIONS ARE CRITICAL PLEASE VERIFY THOSE DIMENSIONS WITH YOUR SALESPERSON

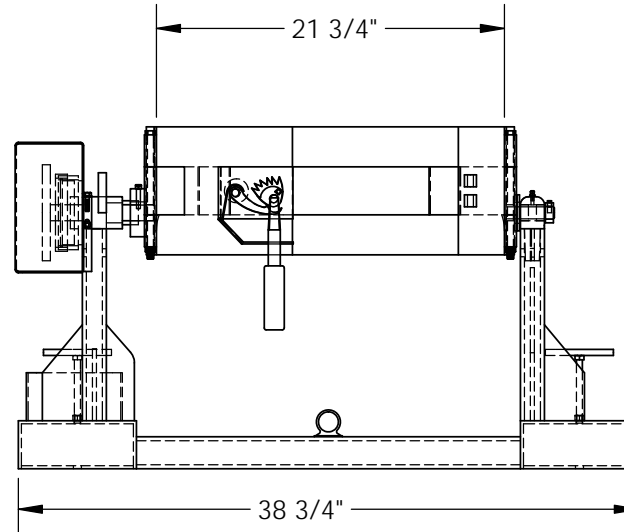
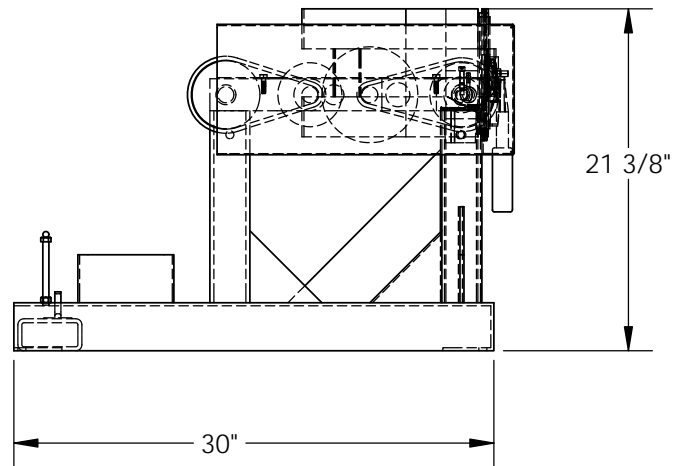
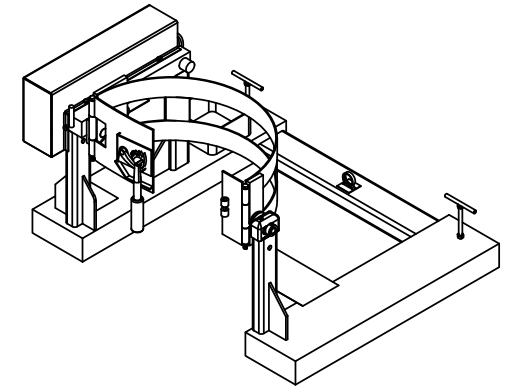

DIMENSION TOLERANCE $\pm 1/4"$

STANDARD FEATURES

MODEL NUMBER IS DCR-205-8
OVERALL WIDTH IS 38 3/4"
OVERALL LENGTH IS 30"
OVERALL HEIGHT IS 21 3/8"
FITS 1- 55 GALLON DRUM
MAX CAPACITY IS 800 LBS.
8' CHAIN (NOT SHOWN)

SPECIAL FEATURES

NONE

APPROVAL

I, THE UNDERSIGNED, AGREE THAT THE PRODUCT AS REPRESENTED SATISFIES DESIGN AND DIMENSION REQUIREMENTS. I ALSO ACKNOWLEDGE MY DUTY TO CONFIRM PRODUCT AND INSTALLATION COMPLIANCE WITH ALL APPLICABLE FEDERAL, STATE AND LOCAL REGULATIONS AND STANDARDS.
ALL SPECIAL UNITS ARE NON-RETURNABLE
[] As drawn [] As marked

Signed: _____ Date: _____

LEAD TIME WILL START UPON RECEIPT OF SIGNED APPROVAL DRAWING

DISTRIBUTOR'S NAME:		P.O.#
VESTIL MANUFACTURING		X
DRAWN BY: CA	DATE: 08/26/2013	W.O.#
REFERENCE: X	SCALE: 1:12	X
QUOTED LEAD TIME: X	QUOTE #	SALES: X
	X	FILE NAME:
		09-007-179