

GROUND LIFT SCISSOR TABLE - EHLTG-4450-4-36

APPROX WEIGHT: 1358.79 lbs.
DOES NOT INCLUDE WEIGHT OF POWER OR PACKAGING!!!

*** ANY ADDITIONS, DELETIONS, OR OMISSIONS MUST BE CORRECTED ON THIS DRAWING AS THIS DRAWING WILL BE CONSIDERED ALL INCLUSIVE ***

ALL GRAPHICS PROVIDED ARE FOR REFERENCE ONLY. IF CERTAIN DIMENSIONS ARE CRITICAL PLEASE VERIFY THOSE DIMENSIONS WITH YOUR SALESPERSON

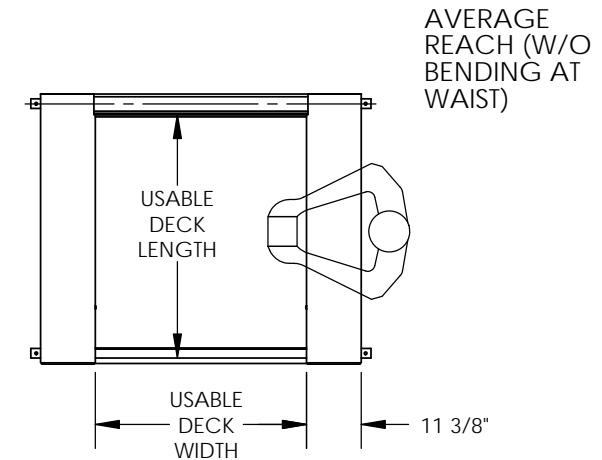
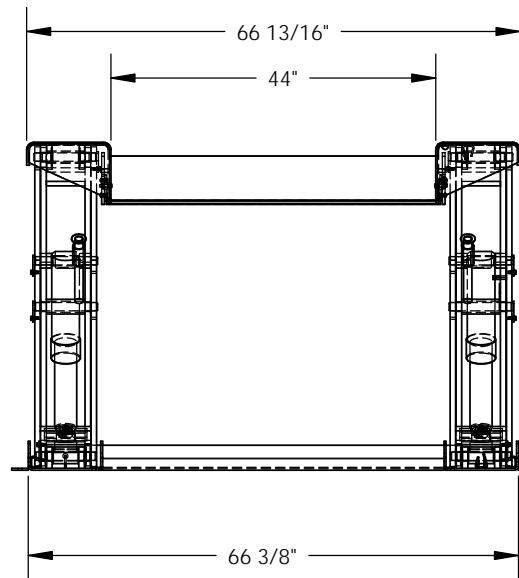
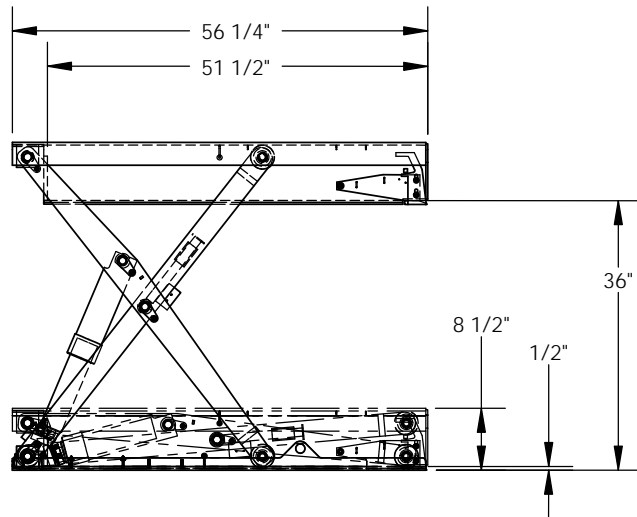

AVERAGE REACH (W/O BENDING AT WAIST)

REMOTE POWER UNIT:
32 1/2" x 12" x 12 1/2"
(L x W x H)
WITH 8' HOSE & CABLE

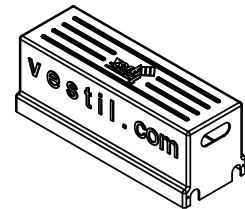

STANDARD FEATURES

MODEL NUMBER IS EHLTG-4450-4-36
 PLATFORM WIDTH (USABLE): 44"
 PLATFORM LENGTH (USABLE): 50"
 OVERALL WIDTH: 66 13/16"
 OVERALL LENGTH: 56 1/4"
 PLATFORM RAISED HEIGHT: 36"
 PLATFORM LOWERED HEIGHT: 1/2"
 CAPACITY: 4,000 LBS
 CONTROL:
 GUARDED FOOT CONTROL, 24V ON 8' CORD
 * HAND CONTROL RAIN TIGHT ON 8' CORD

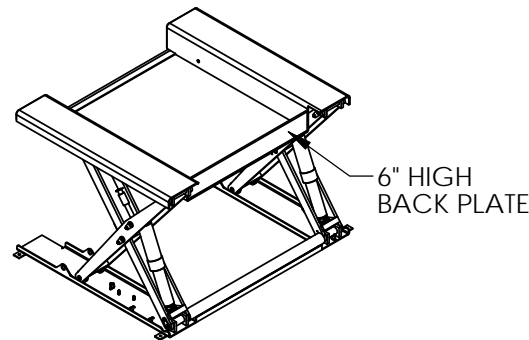

DIMENSION TOLERANCE ± 1/4"

SPECIAL FEATURES

- ACCORDIAN SKIRT (CUSTOMER INSTALLED):
- ONE PIECE (MUST HAVE BACK PLATE)
- TWO PIECES
- KICK OVER BRIDGE PLATE
- OTHER (LIST)

PLEASE CIRCLE SPECIFICATIONS:

POWER	AC	*DC (12V)	*AIR/OIL
MOTOR VOLTAGE	115	208	230 460
DEDICATED CIRCUIT REQUIRED			
MOTOR PHASE	SINGLE	THREE	
CONTROL	FOOT	* HAND	
~ ALL BATTERY CHARGERS ARE 115V AC ~			
* BATTERY CHRG.	REMOTE	ON BOARD	
* CHRG. INDICATOR	YES	NO	

* AVAILABLE AT ADDITIONAL COST

APPROVAL

I, THE UNDERSIGNED, AGREE THAT THE PRODUCT AS REPRESENTED SATISFIES DESIGN AND DIMENSION REQUIREMENTS. I ALSO ACKNOWLEDGE MY DUTY TO CONFIRM PRODUCT AND INSTALLATION COMPLIANCE WITH ALL APPLICABLE FEDERAL, STATE AND LOCAL REGULATIONS AND STANDARDS.

ALL SPECIAL UNITS ARE NON-RETURNABLE
 As drawn As marked

Signed: _____ Date: _____

LEAD TIME WILL START UPON RECEIPT OF SIGNED APPROVAL DRAWING

DISTRIBUTOR'S NAME: **VESTIL MANUFACTURING**

DRAWN BY: DATE: XX/XX/XX

REFERENCE: SCALE: 1:26

QUOTED LEAD TIME: QUOTE #

P.O.#
 W.O.#
 SALES:
 FILE NAME: 04-007-054