

MULTI-PURPOSE DRUM TRUCK - RDBT

APPROXIMATE WEIGHT IS: 88.52 lbs.

*** ANY ADDITIONS, DELETIONS, OR OMISSIONS MUST BE CORRECTED ON THIS DRAWING AS THIS DRAWING WILL BE CONSIDERED ALL INCLUSIVE ***
 ALL GRAPHICS PROVIDED ARE FOR REFERENCE ONLY. IF CERTAIN DIMENSIONS ARE CRITICAL PLEASE VERIFY THOSE DIMENSIONS WITH YOUR SALESPERSON

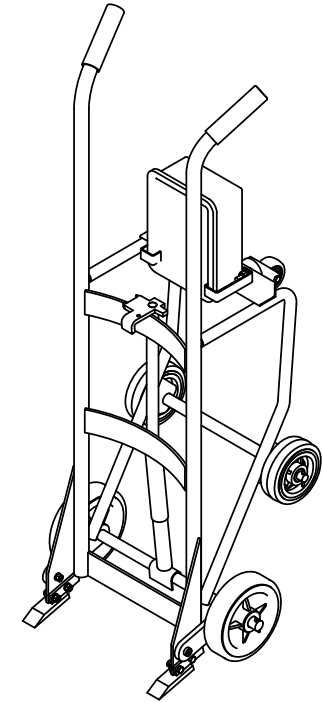
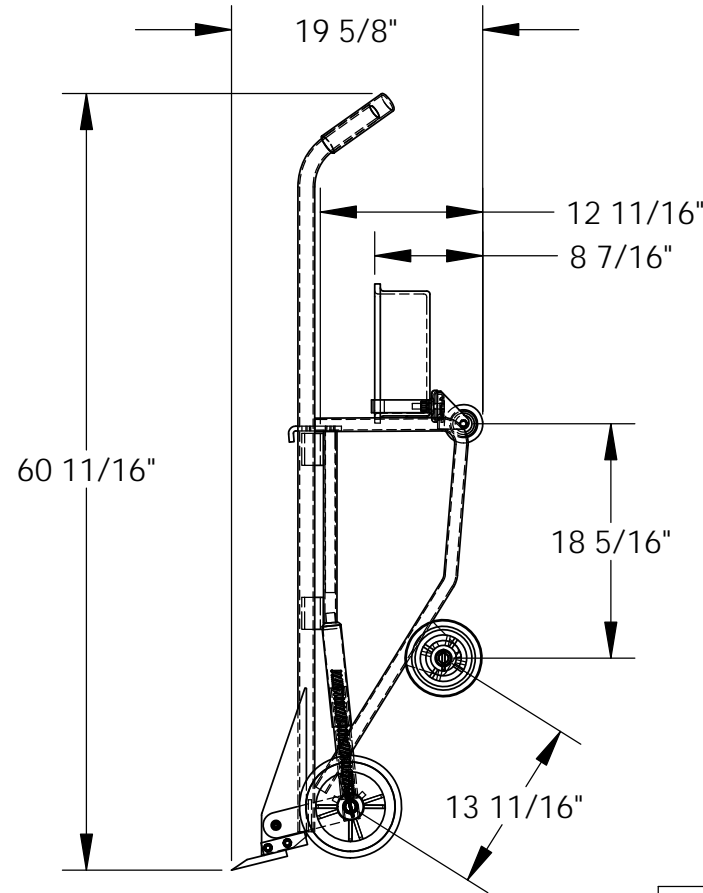
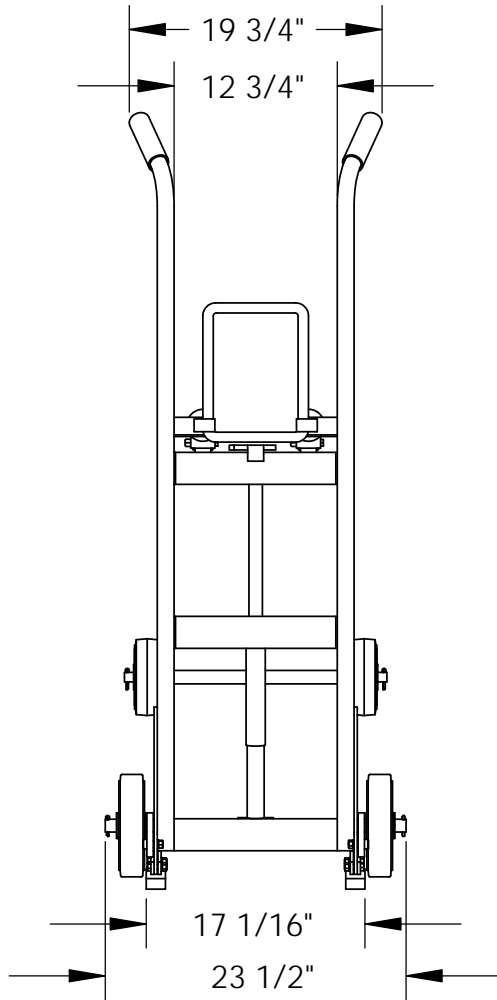

3D VIEW SHOWN FOR REFERENCE ONLY

ALL SPECIAL UNITS ARE NON-RETURNABLE

STANDARD FEATURES

MODEL NUMBER IS RDBT
 CAPACITY IS 1,000 LBS.
 OVERALL WIDTH IS 23 1/2"
 USABLE WIDTH IS 17 1/8"
 OVERALL LENGTH IS 19 5/8"
 OVERALL HEIGHT IS 60 11/16"
 DRAIN HEIGHT IS 8 7/16"
 TIP ANGLE IS 3°
 CASTERS: MOLD ON RUBBER OR POLYOLEFIN
 (2) 3" X 1 1/4", (2) 8" X 2", (2) 6" X 2"
 USED WITH 55 GALLON DRUMS
 DRIP PAN W/ BRACKETS ARE OPTIONAL

SPECIAL FEATURES

NONE

| | | |
|---|--|------------------------------------|
| A P P R O V A L | I, the undersigned, hereby approve this print. This includes my approval of design & dimensions | |
| | <input type="checkbox"/> As drawn | <input type="checkbox"/> As marked |
| | Signed: _____ Date: _____ | |
| LEAD TIME WILL START UPON RECEIPT OF SIGNED APPROVAL DRAWING | | |

| | | |
|--|------------------|--------------------------|
| DISTRIBUTOR'S NAME: VESTIL MANUFACTURING | | P.O.# X |
| DRAWN BY: ND | DATE: 3/14/07 | W.O.# X |
| REFERENCE: X | QUOTE # X | SALES: X |
| | | FILE NAME: 09-007-104 |